

MECHANICAL EQUIPMENT

Products

Acoustic

Spring Jack-Up Mounts



MASON INDUSTRIES, Inc.
Manufacturers of Vibration Control Products

350 Rabro Drive
Hauppauge, NY 11788
631/348-0282
FAX 631/348-0279
Info@Mason-Ind.com
www.Mason-Ind.com

2101 W. Crescent Ave., Suite D
Anaheim, CA 92801
714/535-2727
FAX 714/535-5738
Info@MasonAnaheim.com
www.MasonAnaheim.com

**SPRING
JACK-UP MOUNTS
for CONCRETE
FLOATING FLOORS**

TYPE
FS
DATA SHEET DS-55-3

POSITION 1 FLOOR IN POURED POSITION

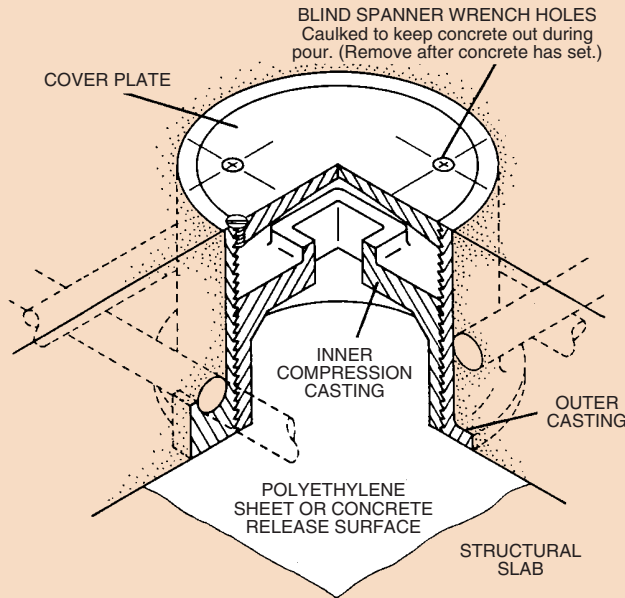

POSITION 2 SPRING & NEOPRENE CUP INSTALLED

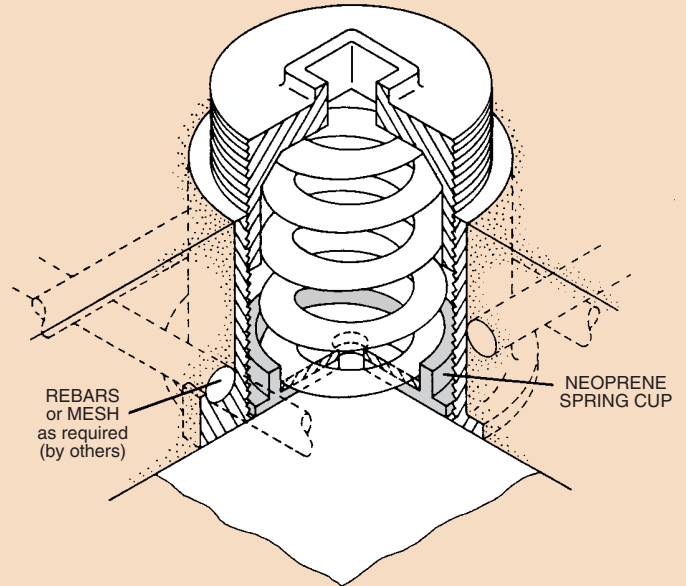

POSITION 3 FLOOR IN RAISED POSITION WITH COVER PLATE INSTALLED

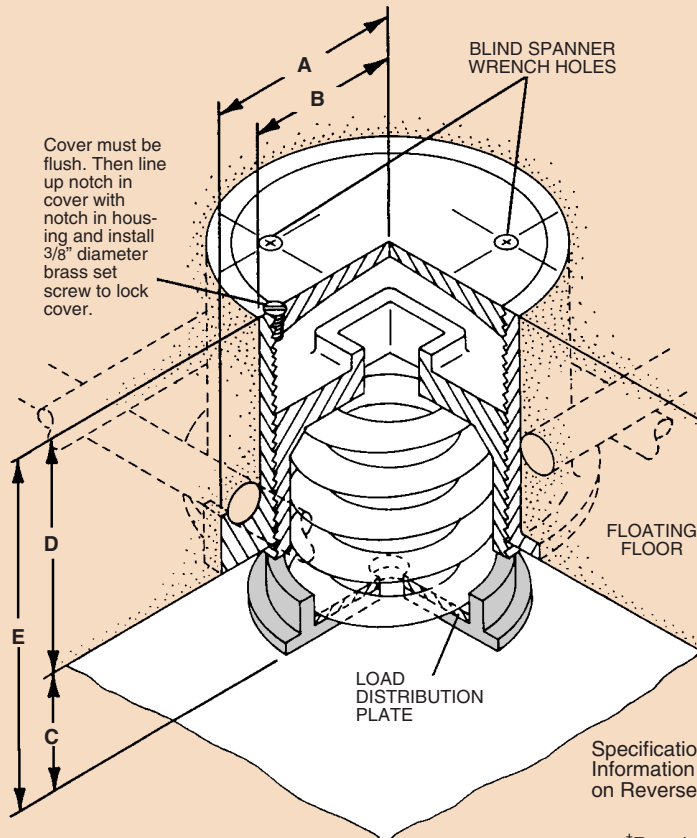

Illustrated housing is for 4" 100mm thick floating floors. Other outside configurations available for 3" 75mm, 5" 125mm and 6" 150mm thick floating floors as required.

†Requires 2" 50mm minimum Air Gap

TYPE FS RATINGS

Size	Rated Capacity (lbs) (kgs)	Rated Defl (in) (mm)	Mount Constant (lb/in) (kg/mm)	Spring Color/Stripe
FS-B-450	450 204	1.31 33	344 6.2	Red
FS-B-750	750 340	1.12 28	670 12.1	White
FS-B-1000	1000 454	1.00 25	1000 18.2	Blue
FS-C-1000	1000 454	1.00 25	1000 18.2	Black
FS-C-1350	1350 612	1.00 25	1350 24.5	Yellow
FS-C-1750	1750 794	1.00 25	1750 31.8	Black*
FS-C-2100	2100 953	1.00 25	2100 38.1	Yellow*
FS-C-2385	2385 1082	1.00 25	2385 43.3	Yellow**
FS-C-2650	2650 1202	1.00 25	2650 48.1	Red*
FS-C-2935	2935 1331	1.00 25	2935 53.2	Red**
FS-B2-450†	450 204	2.00 51	224 4.0	Tan
FS-B2-680†	680 308	2.00 51	340 6.0	Gray
FS-C2-610†	610 277	2.00 51	305 5.4	Green
FS-C2-880†	880 399	2.00 51	440 7.8	Gray
FS-C2-1210†	1210 549	2.00 51	605 10.8	Silver*
FS-C2-1540†	1540 699	2.00 51	770 13.7	Gray*
FS-C2-1870†	1870 848	2.00 51	935 16.6	Silver*

*with RED inner spring **with GREEN inner spring

†Published ratings allow minimum 25% additional travel to solid. For a full 50% specified minimum use the following ratings:

Size	Derated Capacity (lbs) (kgs)	Defl (in) (mm)	Size	Derated Capacity (lbs) (kgs)	Defl (in) (mm)
B2-450	410 186	1.83 46	C2-1210	1010 458	1.67 42
B2-680	565 256	1.66 42	C2-1540	1285 583	1.67 42
C2-880	800 363	1.82 46	C2-1870	1560 708	1.67 42

TYPE FS DIMENSIONS

Type & Size	Housing Dimensions A B	C Air Gap	D Floor Thickness	E Overall Height
FS-B & B2	23/4" 2" 70mm 50mm	Most Common 1" or 2" 25 or 50mm	Minimum 3" 75mm†	Air Gap Plus Floor Thickness
FS-C & C2	31/4" 21/2" 83mm 65mm	Occasionally 3" or 4" 75 or 100 mm	Occasionally 4" 100mm 6" thru 12" 150 or 300mm	

SPECIFICATION INFORMATION

A. Scope

Isolate floating floor from building structure by means of steel spring jack-up isolators and perimeter isolation board.

B. Materials

1. Plastic sheeting: 6 mil(0.15mm)
2. Isolators: Castings or weldments consisting of an outer housing with internal threads and an inner housing with external threads. Outer housing shall have a removable cover plate, lifting flange, and lugs to position the steel reinforcement. The inner housing forms a protective cover over the spring element and shall be designed for spring adjustment. Springs shall be free standing, laterally stable and seated in a minimum 1/4"(6mm) thick neoprene acoustical cup. Spring deflection shall be a minimum of _____ inches under the combined dead and live load. Air gap shall be _____ inches.
3. Perimeter Isolation Board: 3/4"(20mm) thickness 10 lb. fiberglass or 1/2"(12mm) neoprene sponge.
4. Caulking Compound: Non-hardening, non-dry-ing and non bleeding.
5. Floating Floor Drains: Cast iron pipe buckets with cast iron grills and large flanges to cover structural openings complete with waterproofing clamping ring. Upper member shall float with floating floor and sound leakage prevented by an interlocking water trap. Drains shall have weep holes where indicated on drawings.
6. Riser Seals: Steel cylinders containing neoprene sponge seals for both structural and float-ing floors.

C. Floor system adjustment procedure

1. Structural floor must be level, at mount loca-tions, to specifications for upper surface of float-ing floor as mountings are used as screed points. Smoothness at mount locations plus or minus 0.03"(0.7mm).
2. Concrete perimeter forms must be set where required.
3. Cement perimeter material to wall, forms, around columns, etc. as shown on drawings and details.
4. Snap chalk lines showing mounting locations on structural floor. Spray paint or crayon intersec-tions for clearer visibility through 6 mil(0.15mm) polyethylene sheeting.
5. Lay transparent polyethylene sheeting over entire floor area, lapping up and over perimeter isolation material and tape up to maintain posi-tion. Overlap sheeting one foot to increase width, where required and tape all seams.
6. Before placing castings, check to see if threads are greased and inner casting is flush with the bottom of the outer casting as on the Position 1 illustration. If not, turn casting to make it flush.
7. Place castings on maximum 48"(1200mm) cen-ters in locations marked in Step 4 and in accor-dance with layout drawings.
8. Install reinforcing as shown on Mason or con-tract drawings.

9. Pour concrete to required thickness and finish flush with tops of floor mounts in a single pour. Work concrete around mountings and reinforce-ment to eliminate voids and entrapped air. Exer-cise caution to avoid shifting or lifting of mountings.

10. After concrete is fully cured and ready for lift, prepare each casting for spring installation as follow:

A. Remove putty from 3/8" brass cover set screw and spanner holes. Remove set screw and store carefully.

B. Unscrew cover plate by turning counter clock-wise with 1" spanner wrench.

C. Remove inner casting by turning counter clockwise with 1" square "T" wrench.

11. Install neoprene spring cup and proper spring in each locations. Replace inner casting as shown on the Position 2 illustration. Turn inner com-pression casting until it bears against top of spring.

12. Using square "T" wrench, take four clockwise turns on every inner casting. Work can proceed at one location at a time or with a gang of work-ers working simultaneously. Step 12 must be completed before proceeding to Step 13.

13. Take two additional clockwise turns on each inner casting.

14. Repeat Step 13 until floor is lifted to required ele-vation. Approximately eight turns are needed to compress the spring one inch and after springs are at design deflection, each additional eight turns lifts the floor one inch.

15. Install cover plate flush with top of floor and replace brass set screw to lock cover plate in position (see Position 3 illustration). This com-pletes the spring adjustment procedure.

16. Caulk all around perimeter and penetrations as shown on drawing and details.

D. Submittals

1. Isolator layout drawings.
2. Isolator details.
3. Load and deflection curves of all isolators. (Steel spring mountings have dynamic frequen-cies which can be calculated from the deflection so that dynamic frequency tests are never run. To the best of our knowledge, no one has run acoustical tests on this type of installation because the steel springs function very close to the theoretical predictions.)

4. Drain details

5. Perimeter board details

6. Installation Procedure

E. Manufacturer

1. The setting of all isolation material and raising of the floor shall be performed by or under the supervision of the isolation manufacturer.

2. Subject to compliance with the specifications the following products are approved for use. Type FS Jack-up Mountings, AFG-10 Perimeter Board, CFD Floor Drains, SPS Spool Pipe Seals, Type CC-75 and CC-50 Caulking Com-pounds, all as manufactured by Mason Indus-tries Inc.