

MECHANICAL EQUIPMENT

# Engineering

## Hanger Specifications

# Anti-vibration Mounts – Hanger Specifications

## SPECIFICATION F - Spring Hangers

- 1) Spring Hangers shall comprise a steel spring, steel top-cup and rubber bottom cup contained in a steel housing. The rubber bottom cup shall be moulded with a projecting lip to locate and to prevent the steel hanger rod from touching the housing.
- 2) Spring ends shall be ground flat. Deflections at rated loads shall be not less than 25 mm. The spring diameter shall not be less than 80% of its compressed height at the rated load, at which load there shall be at least 50% further travel to solid. At solid the spring material shall be stressed to not more than 80% of its allowable stress.

The spring proportions shall be such as to permit the hanger rod to swing through an arc of 30° before touching the lip of the rubber bottom cup.

Alternatively this paragraph can be omitted to allow the use of standard springs ( which do not provide 30° swing ).

Hangers shall be Type 30 ( alternatively Type HS ), manufactured by ACTOM Mechanical Equipment.

Specification F

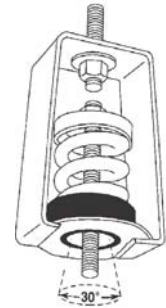

Type 30

## SPECIFICATION G – Combined Spring and Rubber Hangers

- 1) Spring hangers shall comprise a steel spring, steel top cup, rubber bottom cup and rubber element contained in a steel housing. The rubber bottom cup shall be moulded with a projecting lip to locate it and to prevent the lower steel hanger rod from touching the housing. The rubber element shall be moulded with a projecting lip to locate it and prevent the upper steel hanger rod from touching the housing. The rubber element shall be capable of at least 5mm deflection.

Otherwise paragraph (2) applies as in Specification F, alternatively paragraph (2a).

Hangers shall be Mason Type 30N (alternatively type DNHS), manufactured by ACTOM Mechanical Equipment.

Specification G

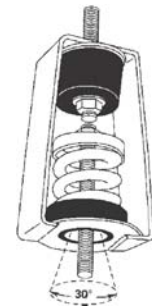

Type 30N

## SPECIFICATION H – Pre-compression Hangers

This can be additional to Specification F or G.

Hangers shall be supplied with a device for pre-compressing the springs to approximately 80% of their rated loads, so as to lock the piping or equipment at a fixed elevation during installation. Then if required the locking device can be removed and the spring released. The spring deflection, before and after pre-compression, shall be indicated by a scale plate.

Hangers shall be Mason Type PC30 or PC30N (alternatively Type PCHS or PCDNHS), manufactured by ACTOM Mechanical Equipment.

Specification H

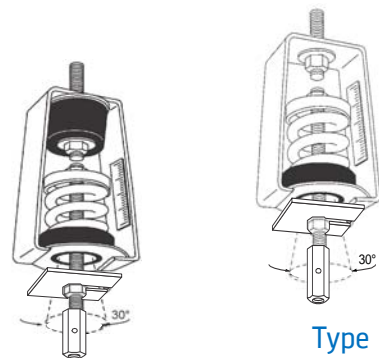

Type PC30N

Type PC30